



Project _____
 AIA # _____ SIS # _____
 Item # _____ Quantity _____ C.S.I. Section 114000

300M
Heritage Prosciutto Slicer



Model 300M



SPECIFIER STATEMENT

Specified slicer features Berkel's hollow ground chromium-plated, carbon steel knife and built-in, two-stone, dual action sharpener. The fly-wheel allows for precision, ultra thin slicing every stroke. The product is automatically fed towards the knife after each stroke. A rear ring guard protects the non-slicing portion of the knife. The product clamp holds the meat from the top, ensuring that it is held securely. Slicer is easy to clean and disassembles quickly without tools.

PERFORMANCE FEATURES

- Nominal 12" (300 mm) hollow ground knife
- Integrated two stone sharpener

EASY TO OPERATE FEATURES

- Low resistance fly-wheel for smooth, easy slicing
- Rear knife guard
- Automatic feeding of the product into the knife
- Clamping device for solidly holding the product

EASY TO CLEAN FEATURES

- Slicer disassembles without tools for easy cleaning

ACCESSORIES (Packaged and sold separately)

- Stand with casters



300M – Heritage Prosciutto Slicer

Approved by _____ Date _____ Approved by _____ Date _____



300M Heritage Prosciutto Slicer

SPECIFICATIONS

Finish/Construction: All food contact areas are stainless steel, anodized aluminum or painted including the pusher, gauge plate, product table, center plate, knife ring guard and one-piece base. Slicer disassembles quickly without tools for easy cleaning.

Knife: Nominal 12" (300 mm) diameter, hollow ground, hardened and polished forged chromium-plated carbon steel.

Cutting Capacity: Carriage handles food up to 8¼" (210 mm) high by 9½" (250 mm) wide or 8¼" (210 mm) diameter.

Slice Thickness: Precision system provides slice adjustment and consistent cuts of hot or cold meats and cheese from tissue thin to ⅜" (5 mm).

Knife Sharpener: Integral top mounted, two stone, dual-action system for a lasting, razor-sharp edge.

Knife Ring Guard: Rear guard covers non-slicing portion of knife edge.

Manual Operation: No motor.

Warranty: Parts, labor and travel coverage for one year, exclusive of wear items.

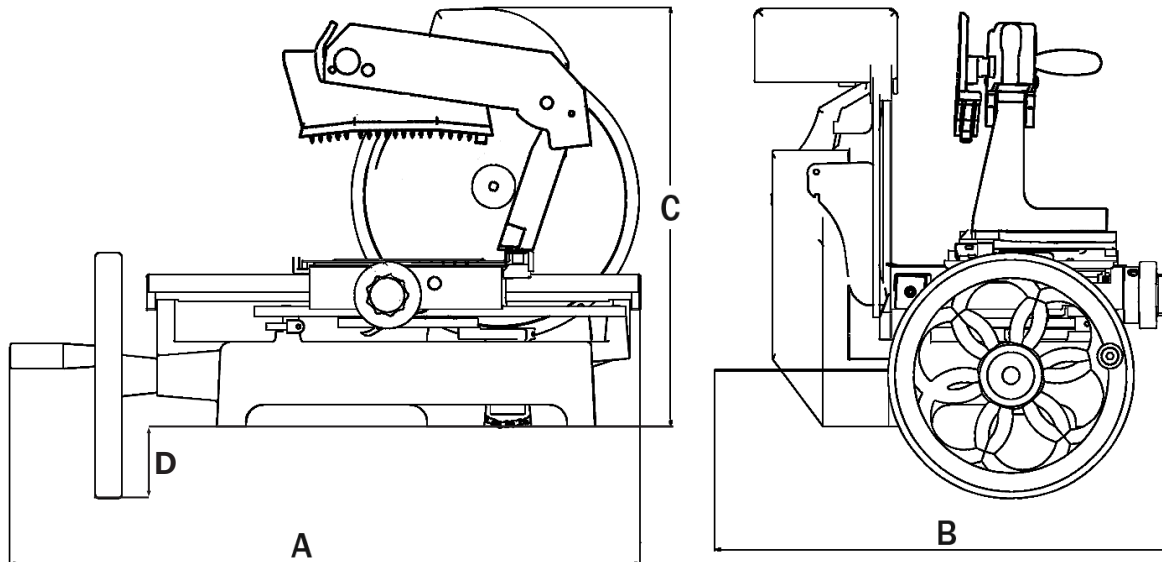

MODEL NUMBER	CUTTING CAPACITY	SLICE THICKNESS	KNIFE DIAMETER	PRODUCT DIMENSIONS			
				DEPTH A	WIDTH B	HEIGHT C	HEIGHT D
300M	9½" (250 mm) wide 8¼" (210 mm) high 8¼" (210 mm) diameter	to ⅜" (5 mm)	12" (300 mm)	31½" (800 mm)	23½" (597 mm)	22½" (572 mm)	2½" (64 mm)

MODEL NUMBER	WEIGHT		BOX DIMENSIONS		
	NET	SHIP	DEPTH A	WIDTH B	HEIGHT C
300M	70 lbs. (32 kg)	154 lbs. (70 kg)	32" (815 mm)	40" (1020 mm)	40" (1020 mm)

As continued product improvement is a policy of Berkel, specifications are subject to change without notice.