

SLICING

Berkel**300M**
HERITAGE PROSCIUTTO SLICER

Model 300M

**FEATURES**

Berkel Model 300M Heritage Prosciutto slicer features Berkel's hollow ground chromium-plated, carbon steel knife and built-in, two-stone, dual-action sharpener. This slicer is perfect for ultra thin slicing in front of customers. The fly-wheel allows for precision slicing, every stroke. The product is automatically fed towards the knife after each stroke. A rear ring guard protects the non-slicing portion of the knife. The product clamp holds the meat from the top, ensuring that it is held securely. The 300M is easy to clean and disassembles quickly without tools.

- 300M** Manual Fly Wheel Slicer

STANDARD FEATURES

- Low resistance fly-wheel for smooth, easy slicing.
- Rear knife guard.
- Classic styling with the "traditional" Berkel red color.
- Integrated two stone sharpener.
- Nominal 12" (300 mm) hollow ground knife.
- Clamping device for solidly holding the product.
- Automatic feeding of the product into the knife.
- Handles product 7" high by 8½" wide.
- Slices product 7" round.
- Slicing up to 3/16" in thickness.

ACCESSORIES (Packaged & Sold Separately)

- 300M-STANDC (with Casters)



The 300M is the gold standard for "front-of-the-house theatre slicing"

Berkel

a division of ITW Food Equipment Group LLC

P.O. Box 696 ■ Louisville, KY 40201 ■ Toll-free: 1-800-814-2028 ■ Local: 502-778-2791 ■ Quote & Order Fax: 1-800-444-0602

Berkel**300M**
HERITAGE PROSCIUTTO SLICER**SPECIFICATIONS**

Finish/Construction: All food contact areas are stainless steel, anodized aluminum or painted including the pusher, gauge plate, product table, center plate, knife ring guard and one-piece base. Slicer disassembles quickly without tools for easy cleaning.

Knife: Nominal 12" (300 mm) diameter, hollow ground, hardened and polished forged chromium-plated carbon steel.

Cutting Capacity: Carriage handles food up to 7" (178 mm) high by 8½" (216 mm) wide or 7" (178 mm) diameter.

Slice Thickness: Precision system provides slice adjustment and consistent cuts of hot or cold meats and cheese from tissue thin to ⅜" (5 mm).

Knife Sharpener: Integral top mounted, two stone, dual-action system for a lasting, razor-sharp edge.

Knife Ring Guard: Rear guard covers non-slicing portion of knife edge.

Manual Operation: No motor.

Warranty: All parts, service and travel coverage for one year, excluding wear items.

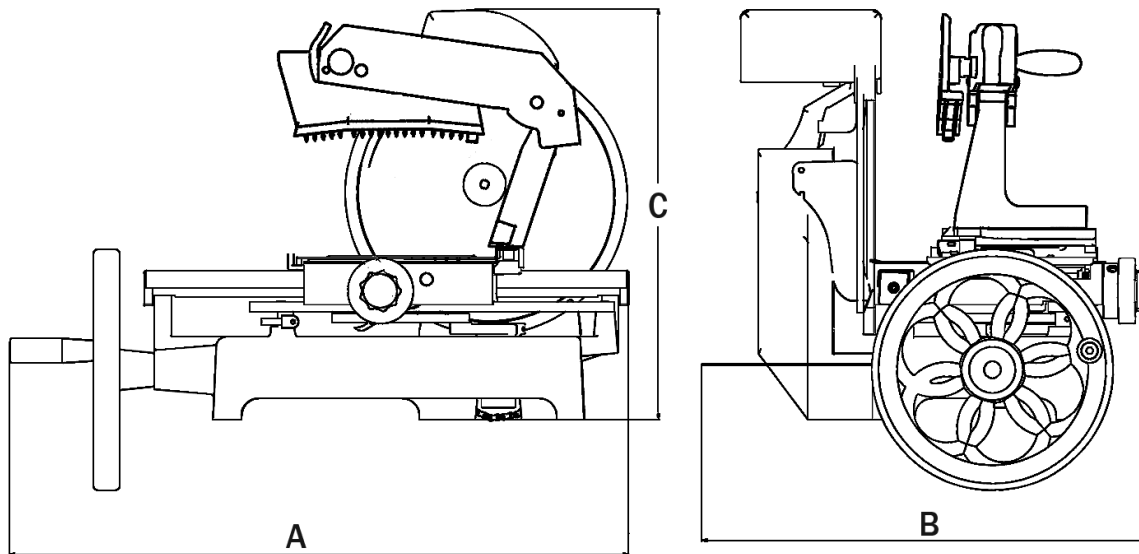

MODEL NO.	CUTTING CAPACITY	SLICE THICKNESS	KNIFE DIAMETER	PRODUCT DIMENSIONS		
				DEPTH A	WIDTH B	HEIGHT C
300M	8½" (216 mm) wide 7" (178 mm) high 7" (178 mm) diameter	to ⅜" (5 mm)	12" (300 mm)	31½" (800 mm)	23½" (597 mm)	22½" (572 mm)

MODEL NO.	WEIGHT		BOX DIMENSIONS		
	NET	SHIP	DEPTH A	WIDTH B	HEIGHT C
300M	70 lbs. (32 kg)	154 lbs. (70 kg)	32" (815 mm)	40" (1020 mm)	40" (1020 mm)

Berkel a division of ITW Food Equipment Group LLC

P.O. Box 696 ■ Louisville, KY 40201 ■ Toll-free: 1-800-814-2028 ■ Local: 502-778-2791 ■ Quote & Order Fax: 1-800-444-0602

NOTE: As we continually strive to improve our products, specifications are necessarily subject to change without notice.